

OSLO 1200

Vinyl furniture

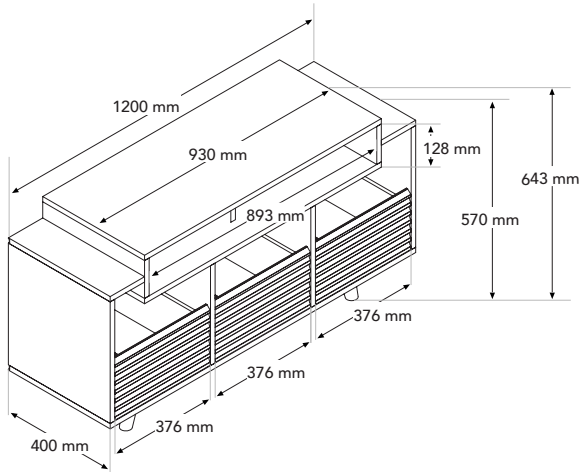

DIMENSIONS



MAXIMUM LOAD

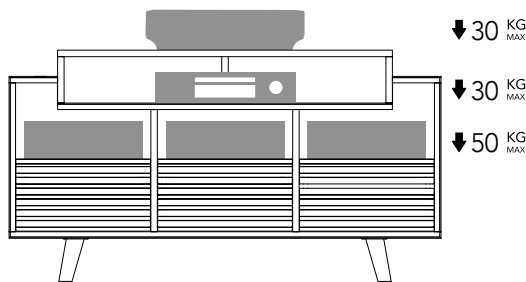

PRODUCT CODES

● **Finish :** Black Satin / Walnut
EAN : 3700795181157
SKU : NOROSVI120ABSWN

● **Finish :** White / Clear Oak
EAN : 3700795181164
SKU : NOROSVI120AWTOK

DESCRIPTION

The ultimate vinyl cabinet for demanding collectors.

The Norstone Oslo 1200 is a piece of furniture designed to meet the needs of vinyl collectors and music lovers. At 120 cm wide, it offers generous storage space, combining practicality with modern design.

Available in two finishes - Black Satin / Walnut and White / Clear Oak - it fits perfectly into any interior, adding a contemporary, elegant touch.

This model has three drawers, each with space for up to 80 vinyl records. The drawers feature an innovative grip system that prevents vinyl from slipping out, providing secure and practical organisation.

The Oslo 1200 has also been designed to showcase your audio equipment. With 89 cm of space reserved for your electronics, it can easily accommodate an amplifier, a network player or any other device essential to your hi-fi setup. The perfectly sized top shelf is ideal for displaying your turntable and creating a refined, functional listening area.

Make no more compromises between style and performance : with the Norstone Oslo 1200, you get a piece of furniture that matches your passion for music.



DESIGN

Finishes : *Black satin / Walnut
White / Clear Oak*

Structure : *Melamine*

MAXIMUM LOAD

Top shelf : *30 kg*

Per drawer : *50 kg*

USEFUL DIMENSIONS

External dimensions (W x H x D) : *1200 x 643 x 400 mm*

Shelves (W x H x D) : *893 x 128 x 400 mm*

Per drawer (W x D) : *376 x 370 mm*

PACKAGING

Delivered disassembled with screws kit , mounting instructions and tools

Quantity / box : *1*

Type : *Brown cardboard*

Dimensions (W x H x D) : *1310 x 200 x 570 mm*

Gross weight : *51,9 kg*

Net weight : *48,5 kg*



ALSO AVAILABLE



OSLO
800